



# Pure Air Technology

## Pure Air Technology



# Pure Air AIR PURIFICATION

## The Science

**Pure Air air purifier** process removes contaminants from air and surfaces by combining two very powerful purifying technologies - **Photoplasma** and **Photochemistry**. While these methodologies have been well studied and documented by the scientific community, the synergy of their interaction produces a unique and a superlative way of cleaning air and surfaces of contaminants.



**Photochemistry** is the chemical reaction or change in material caused by exposure to light energy. The process typically requires the use of photons in the ultraviolet spectral range. Ultraviolet light in this range is useful for disinfection purposes. When a strong enough ultraviolet light is present, it becomes useful in the destruction of contaminating organic compounds. Almost all indoor contaminants are organic, such as toxic volatile organic compounds, dust particles like dander, hair, dust mite feces, etc., and biological contaminants like bacteria, viruses, and fungi. Photochemistry can break down these harmful organic molecules. Ultraviolet light with enough energy such as in the 100-280 nanometer wavelength range can also break down the electron bonds of an organic molecule.

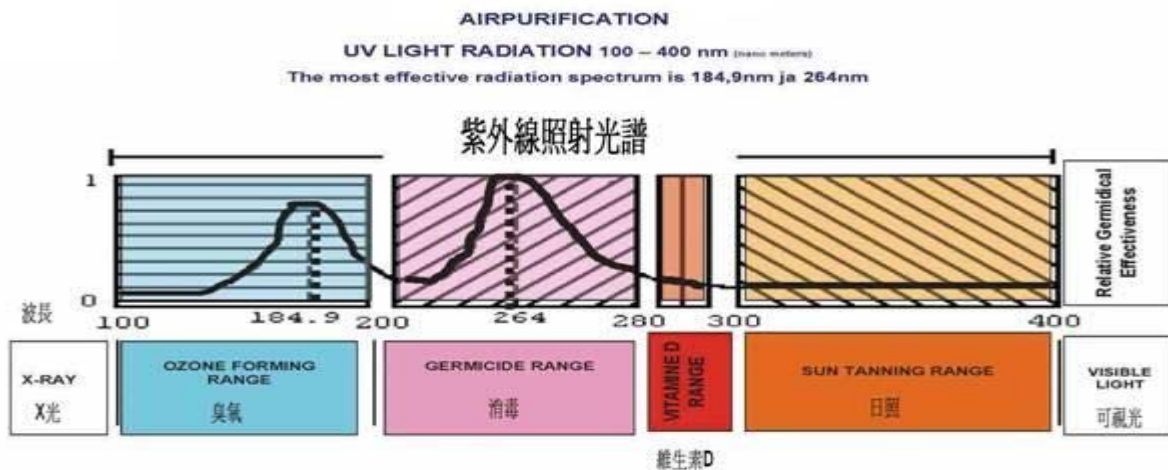

Ultraviolet wavelengths in the 100-280 nanometer bandwidth not only break down electron bonding of an organic molecule, but also initiate the formation of a cold gas plasma. We excite gases by the energy from ultraviolet light waves and create a highly energized gaseous state. The plasma, or highly energized gaseous state, is aggressive and highly

## Pure Air AIR PURIFICATION

reactive and contains excited atoms and molecules, ionized gases, radicals, and free electrons. It can destroy just about all organic contaminants.

The destruction mechanism primarily involves the photodissociation of molecular oxygen leading to the formation of highly oxidizing species, such as atomic oxygen, molecular singlet oxygen and ozone. These reactive species interact with contaminants converting most to carbon dioxide and water. The UV light also creates electron ejection of organic molecules that produces additional free radical creation. The radicals react with oxygen producing hydroperoxide ions, with the whole process creating a chain reaction with

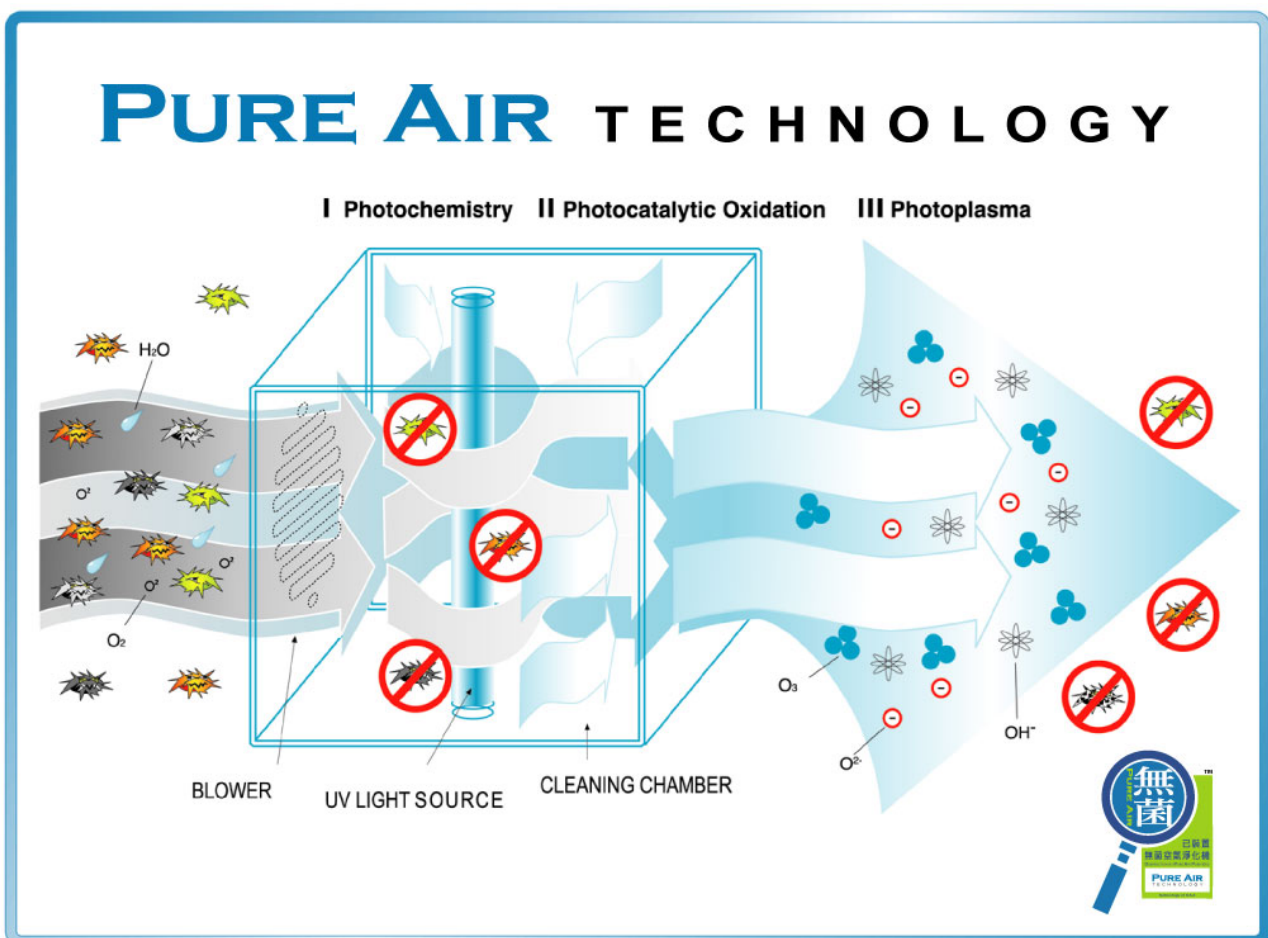

organic compounds triggering further oxidation. When additional hydrogen is added as in the form of water or water vapor (humidity), the highly oxidative species hydroxyl radicals is created. These radical ions are stable and are very destructive to organic contaminants because they steal hydrogen atoms from the organic materials, leaving decaying carbon ions. The theft of hydrogen from organic molecules forms even stronger hydroxyl radical bonds with even higher oxidation potential. This entire process turns into a chain reaction - the breakdown and formation of new hydroxyl radicals results in the continual decay of organic material.

**Fine particulates were sunk**

The ejecting of electrons from a molecule by high energy ultraviolet light is called the photoelectric effect, and it can be further enhanced by irradiating what is called a "photoelectron emitting member" to eject more electrons. Such a photoelectron emitting member is contained in Pure Air air purifiers. The photoelectrons ejected are used to charge fine particles in a gas which are then removed from the air stream as they attach to oppositely charged surfaces. This electrically charging of dust and other particulates can remove particles as small as .001 micron. It should be noted that each of the electron ejections can cause multiple ionization events. For example, in the photoelectric effect, the photon undergoes only one interaction, yet thousands of ionizations can be caused by the resultant electron and its products.



**The PureAir** process combining photochemistry and photoplasma has been reported to be extremely potent in removing contaminants from the air and surfaces. There is scientific evidence that surfaces can be decontaminated 100 - 2000 times faster than with other purifying methods.

## Reduce biological contaminants

The highly oxidative species hydroxyl radicals are very destructive to organic contaminants because they steal hydrogen atoms from the organic materials, leaving decaying carbon ions. The theft of hydrogen from organic molecules forms even stronger hydroxyl radical bonds with even higher oxidation potential. This entire process turns into a chain reaction & the breakdown and formation of new hydroxyl radicals results in the continual decay of organic material.

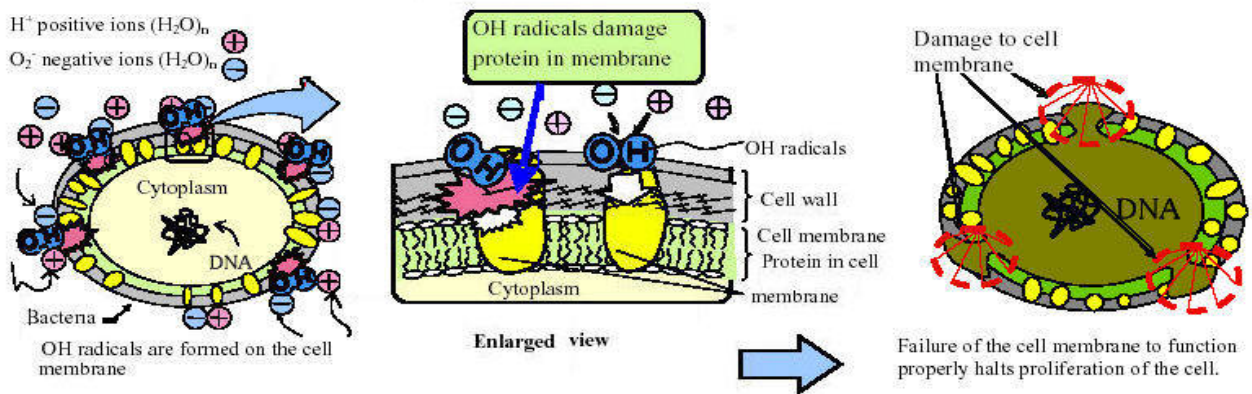

Bacteria were analyzed using an electron microscope.

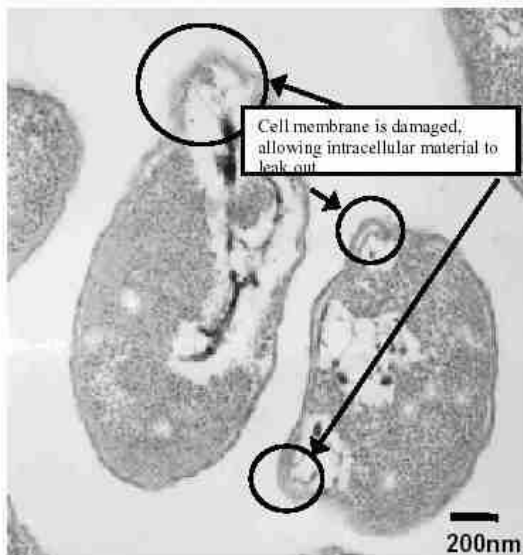

Photoplasma present  
The cell membrane is damaged, allowing intracellular material to leak out.

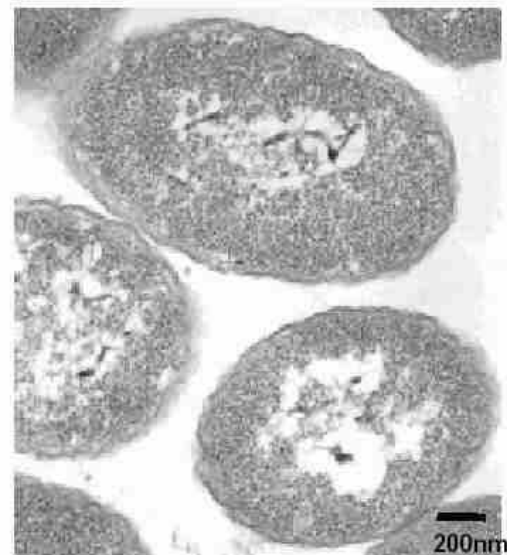

No Photoplasma present  
Cell morphology is normal

### The results

confirmed the fact that the cell membrane was damaged by exposure to the ions and that intracellular material had leaked out. This means that the ions cleaved the protein in the bacteria's cell membrane and opened holes in it, causing the membrane to malfunction. As a result, the bacteria are regarded as inactivated, and inactivated bacteria fail to multiply.

## Electronics

While Pure Air process utilizing photoplasma and photochemistry is extremely effective, it can only be dependable in its performance if the electronic power to the ultraviolet lamp is consistent. Most manufacturers using ultraviolet light for purifying use old-time, inexpensive, magnetic ballasts to power the lamp resulting in electrical inefficiency and unpredictable purifying. Pure Air Research and Development Department has developed a propriety power module that provides state-of-the-art

electronics to this most important area. Pure Air's Radiance Control Power Module™ (R.C.P.M.) is unique in the world in its performance. It controls the dynamic nature of the electrical input which, in turn, controls the resulting output (radiance) of the ultraviolet lamp.

This provides consistent purifying at

an extremely high level, cost effective electrical efficiency, and extended lamp performance.

The R.C.P.M. is also small (1 1/4" x 3 1/2" x 1") and weights only ounces allowing Pure Air products to be compact and light weight.

In addition, the R.C.P.M design operates on 12VDC providing one of the safest devices in the market. Along with safety, the 12VDC system is easily used all over the world. No more worry about countries varying electrical systems using 110VAC or 240VAC. A simple AC/DC adapter is all that is needed.

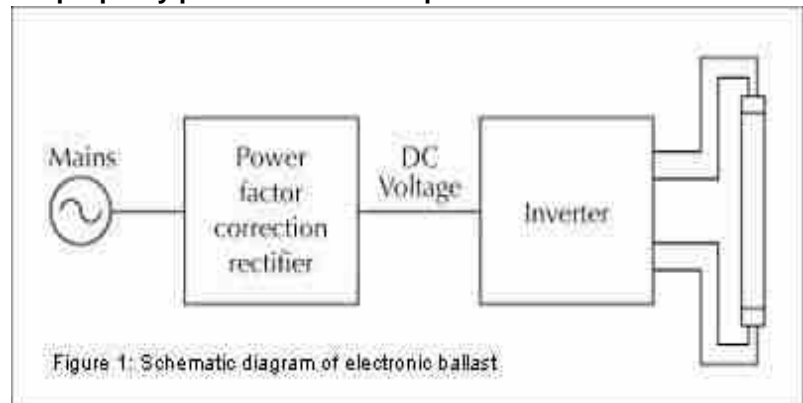

## What can Pure Air air purifier can do



How can Pure Air air purifier do for the air we are breathing ?

### **Eliminate Unpleasant Odors From –**

mustiness, chemicals, pets, tobacco smoke, cooking, Garbage, fires

### **Reduce Biological Contaminants –**

bacteria, viruses, mold, mildew, dander, pollen, dust mites

### **Neutralize Chemical Gases –**

volatile organic compounds(VOC's), formaldehyde, benzene, pesticides, aerosol hydrocarbons, paints, cleaners, etc

### **Remove Particulates From The Air –**

dust, soot, smoke, fabric particles, etc

## UV DOSAGE FOR DESTRUCTION

**Ultraviolet energy levels at 254 nanometer unit wavelength required for 99.9% destruction of various microorganisms:**

<b>BACTERIA</b>	<b>Common Name</b>	<b><math>\mu\text{W}/\text{cm}^2/\text{sec.}</math></b>
Bacillus Anthracia	Anthrax Virus (not spores)	8,700
Agrobacterium Tumefaciens	Crown Gall Disease (plants)	8,500
Bacillus Megatherium	Wet Wood Disease	2,500
Bacillus Subtilis	(Vegetative)	11,000
Clostridium Tetany	Tetanus/Lockjaw	23,000
Corynebacterium Diphtheria	Diphtheria	6,500
Escherichia Coli	E-Coli	7,000
Legionella Bozemanil	Pontiac Fever	3,500
Legionella Dumoffii	Pontiac/Legionnaires	5,500
Legionella Gormanil	Pontiac/Legionnaires	4,900
Legionella Micdadei	Pontiac/Legionnaires	3,100
Legionella Longbeachae	Pontiac/Legionnaires	2,900
Legionella Pneumophila	Legionnaires Disease	2,760
Leptospira Interrogans	Infectious Jaundice/Leptospirosis	6,000
Mycobacterium Tuberculosis	Pulmonary Tuberculosis	10,000
Neisseria Catarrhalis	Meningitis Endocarditis, Pneumonia, Bronchitis, Otitis Media, Sinusitis	8,500
Proteus Vulgaris	Urinary Tract Infection, Bacteremia, Pneumonia and Focal Lesions	3,900
Pseudomonas Aeruginosa	Laboratory Strain	3,900
Pseudomonas Aeruginosa	Enviromental Strain	6,900
Rhodospirillum Rubrum	Bacterium	6,200
Salmonella Enteritidis	Gastroenteritis, Enteric Fever, Osteomyelitis	7,200
Salmonella Paratyphi	Para-Typhoid Fever, Enlargement of Spleen	6,100
Salmonella Typhimurium	Gastroenteritis	15,200
Salmonella Typhose	Typhoid Fever, Enteric Fever, Typhus Abdominales	6,000
Serratia Marcescent	Septicaemia Abscesses, Burn Infections, Osteomyelitis	6,200
Shigella Dysenteriae	Dysentery – Enteric Infection	4,200
Shigella Flexneri	Dysentery	3,400
Shigella Sonnei	Enteric Infection	7,000
Staphylococcus Epidermidis	Bacteraemia, Wound Infection, Endocarditis, Catheter-Related Sepsis, UT I, Toxic Shock Syndrome, Eye Infection, Osteomyelitis	5,800
Staphylococcus Aureus	Staphy Lococcal Disease, Impetigo, Toxic Shock Syndrome, Food Poisoning	7,000
Streptococcus Faecalis	Urinary Tract Infection and Bacterial Endocarditis	10,000
Streptococcus Hemolyticus	Various Infections	5,500
Streptococcus lactic	Various Infections	8,000



## UV DOSAGE FOR DESTRUCTION

Viridans Streptococci	Invasive Infections	3,800
Vibrio Cholera	Cholera	6,500

### MOLD SPORES

Mucor Ramosissimus	Sinuses, Brain, Eyes, Lungs & Skin Infections	35,200
Penicillium Expensum		22,000
Penicillium Roquetorti	Green	26,400

### ALGAE

Chlorella Vulgaris	Green Algae	22,000
--------------------	-------------	--------

### VIRUSES

Bacteriophage	E. Coli / Bloody diarrhea Hemorrhagic Colitis	6,600
Hepatitis Virus	Hepatitis	8,000
Influenza Virus	Influenza	3,400
Poliovirus	Polio	21,000
Rotavirus	Rota Virus	24,000
Small Pox Virus	Small Pox	9,000

### CYST

Giardia Lamblia	Giardiasis`	5,000 – 10,000
Chryptosporidium	Diarrheal Disease	5,000 – 10,000

### YEAST

Bakers Yeast	Trichosporon	8,800
Brewers Yeast	Brewers Yeast	6,600
Common Yeast Cake	Yeast Cake	13,200
Saccharomyces Eliipsoideus	Saccharomyces	13,200

## Air Cleaning - Comparisons

0= no effect, 1= little effect, 2= some effect, 3= medium effect, 4= strong effect, 5= most effective

Air Cleaning	Pure Air Plasma	HEPA Filters	Electronic Filters	Carbon Filters	Negative Ionizers	Germicidal UV Light	Ozone Generators
Airborne Bacteria	5	3	2	1	1	4	5
Surface Bacteria	5	0	0	0	0	0	5
Airborne Viruses	5	1	1	0	1	4	5
Surface Viruses	5	0	0	0	0	0	5
Airborne Particulates	3	3	3	1	3	0	1
Gasses	5	0	0	0	0	2	4
Odors	5	0	0	3	0	0	5
Destroys Contaminants	5	0	0	0	0	3	5
Coverage Area	5	2	2	2	2	2	5
Safety and Reliability	5	3	3	3	3	3	3

## Pure Air AIR PURIFICATION

By adding negative ions to our indoor air, we are restoring the natural balance of ions and eliminating many of the pollutants. These air ions are important to you because if there are a high proportion of negative ions you will feel lively, uplifted, enthusiastic, not to mention, healthier. It is possible with modern technology to take control of the electric state of our indoor environments by generating negative ions which can be put back into the air through negative ion generators; becoming electrons created as a byproduct of electrical or UV discharge. These electrons then attach themselves to an oxygen molecule making up the negative ion. The negative ions will attach themselves to airborne toxins and other large pollutants and drop them from the air, that alone making the air much healthier and cleaner. Our Pure Air process does a great job at purifying the air as one of its multifaceted functions

### Safety



resulting in consistent optimal operation, extended UV lamp life and overall dependability.

**Safety voltage-** All Pure Air purification products use a proprietary, safe, lightweight, low-voltage method of power. Pure Air did away with the potentially hazardous voltages used in other devices, using instead a unique and 100% safe 12-volt circuit – a voltage level not that much higher than you'd find in the average, battery operated home fire alarm! In addition SafeVolt™ circuitry provides a stable, controlled supply of power



**Ozone safety-** Pure Air's purifying system combines the methods of ultraviolet light, photocatalytic oxidation and photoplasma. Whenever a purifying plasma is created using air or oxygen, a certain amount of ozone will also be created. This small amount of ozone is very helpful in the total effort of contaminant reduction. However, too much ozone is not

desirable in inhabited spaces. Pure Air engineers its air purifiers for continuous use in inhabited areas and guarantees that ozone levels in an inhabited area will not rise above safe limits as prescribed by the US FDA, EPA and OSHA when used as intended.

### Effectiveness

The combination of ultraviolet light and plasma has been reported to be extremely potent in removing contaminants from surfaces. As an example and for comparative purposes, it has been estimated that removing biological contaminants from surfaces by corona discharge created ozone may take 10 hours. Ultraviolet light in the highly bactericidal range of 253.7 nanometers would take 1 hour for the same result. Corona discharge ozone and ultraviolet light combined would achieve the same result in 1.5 minutes. However, the use of a broader and more energetic ultraviolet bandwidth combined with the resulting plasma would clean the same surface in 20 seconds.